

User Manual

Please read this user manual throughout before using

Ver:A

Preface

All internal technologies of this product are protected, including device, software and trademark. Reproduction in whole or in part without written permission is prohibited.

All brands and trademarks of SWIT Electronics Co., Ltd. are protected and other relative trademarks in this user manual are the property of their respective owners.

Due to constant effort of product development, SWIT reserves the right to make changes and improvements to the product described in this manual without prior notice.

The warranty period of this product is 2 years, and does not cover the following:

- (1) Physical damage to the surface of the products, including scratches, cracks or other damage to the LCD screen or other externally exposed parts;
- (2) The LCD dot defects are not over three;
- (3) Any damage caused by using third-party power adaptors;
- (4) Any damage or breakdown caused by use, maintenance or storage not according to the user manual.
- (5) The product is disassembled by anyone other than an authorized service center.
- (6) Any damage or breakdown not caused by the product design, workmanship, or manufacturing quality, etc.

* Any sales personnel have no rights to provide additional warranty.

For any suggestions and requirements on this product, please contact us through phone, fax, Email, etc.

SWIT Electronics Co., Ltd.

Address: 10 Hengtong Road, Nanjing Economic and Technological Development Zone,
Nanjing 210038, P.R.China

Phone: +86-25-85805753

Fax: +86-25-85805296

Email: contact@swit.cc

<http://www.swit.cc>

Warning

1. In order to reduce the risk of fire and electrical shock, do not lay this product in rain or damp places.
2. Please keep away from the strong magnetic field; it may cause the noise of the video and audio signals.

The power

1. Please use the power adapter provided or recommended by the manufacturer in order to avoid damage.
2. For a third party power adapter, please make sure the voltage range, supplied power, and polarity of power lead are fit.
3. Please disconnect the power cable under the following situations:
 - (A). If you do not operate this monitor for a period of time;
 - (B). If the power cable or power adaptor is damaged;
 - (C). If the monitor housing is broken.

The monitor

1. Please don't touch the screen with your fingers, which would probably deface the screen.
2. Please don't press the screen; the LCD is extremely exquisite and flimsy.
3. Please don't lay this product on unstable place.

Cleaning

1. Please clean the screen with dry and downy cloth or special LCD cleanser.
2. Please do not press hard when cleaning the screen.
3. Please do not use water or other chemical cleanser to clean the screen.
The chemical may damage the LCD.

Contents

Preface	2
Maintanance	3
Contents	4
Packing list	4
Introduction	4
Installation Dimensions	5
Operation Instruction	7
Front Panel	7
OSD	8
Rear Panel	10
Main Menu	11
Specification	21
Trouble-Shooting	22

Packing list

No.	standard package	details
1	monitor	× 1
2	user manual	× 1
3	warrantee card	× 1
4	Battery plate (V-mount or Gold mount option)	× 1
5	tabletop stand	× 2
6	power cord	× 1
7	left 、right side rack	× 2

Introduction

BM-U173 adopts TFT-LCD panel, with resolution of 3840x2160 and 178° x 178° wide viewing angle. It supports 2 x 12G/6G/3G/HD/SD-SDI, 1x HDMI2.0, and 2 x 12G/6G/3G/HD/SD-SDI, 2 x 3G/HD/SD-SDI loop through, plus earphone and speaker out.

Features:

- 17.3 inch UHD(3840x2160) panel
- 4K/UHD interface(2x12G-SDI&2x3G-SDI input, 4xSDI loop out, 1xHDMI 2.0 input)
- 16ch audio bar display, with any selected 2ch output
- Support waveform selection display(Y, Cb, Cr, R, G, B) and single line selection mode.
- Vector scope, R/G/B/Y histogram, bi-color focus assist
- 3D Lut(17x17x17) accurate color correction
- Dynamic UMD and TALLY(TSL3.1,4.0) display
- Markers
- Firmware upgrade and User Luts upload via USB
- Eco mode

Installation Dimension

The main body (in mm)

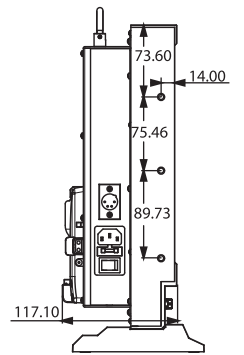
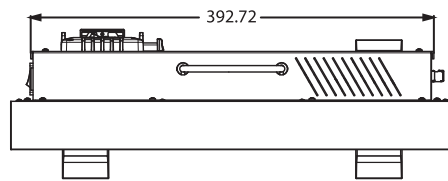
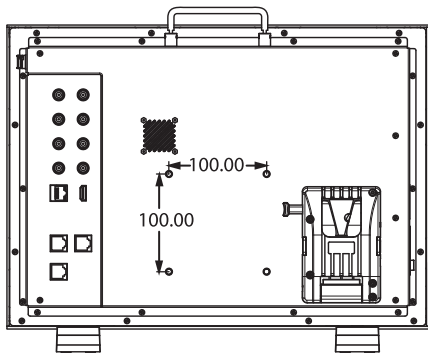
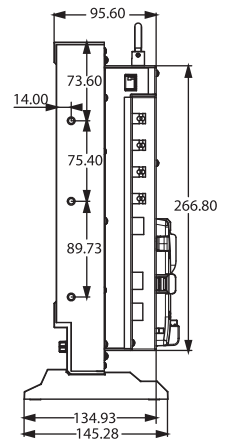
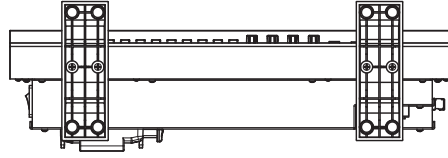
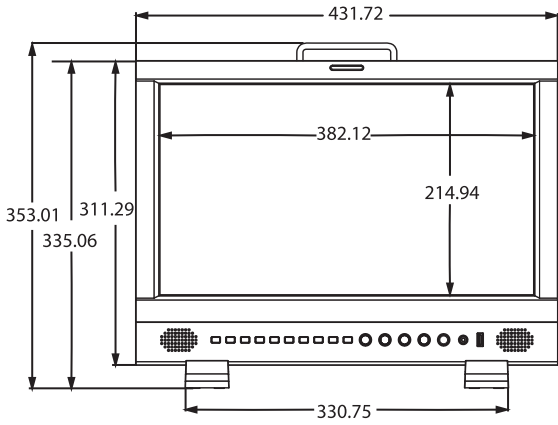

Main body and side racks

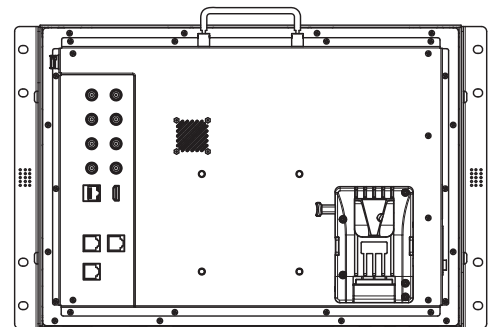
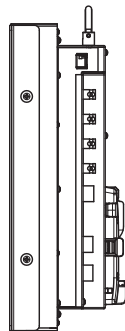
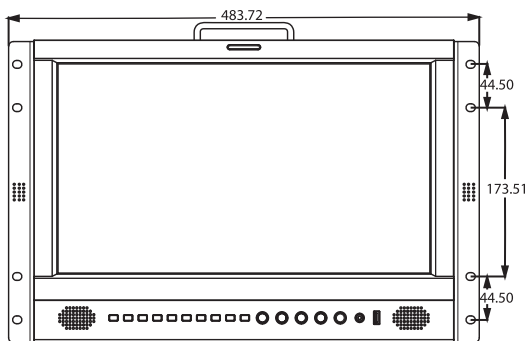

Install the side frame

Install introduction:

1. Place the side rack on the side of the product ,align the hole position with the hreaded hole on the product ,and fix the screws in the package box clockwise.
2. Install the left and right side rack products on the 19-inch standard cabinet as shown in figure 3.

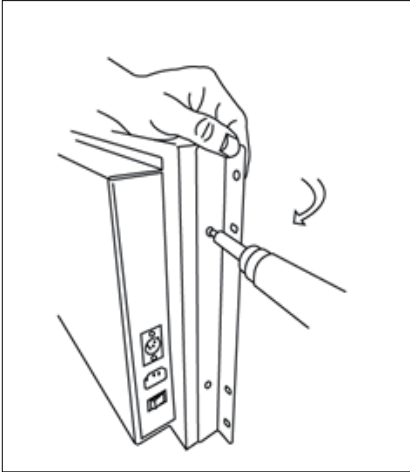

Figure 1

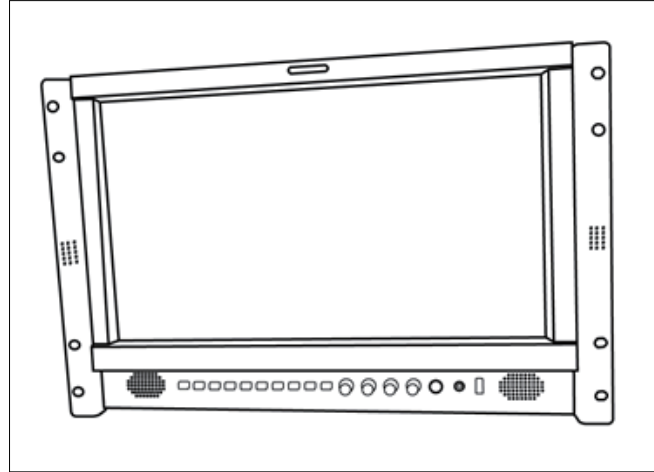

Figure 2

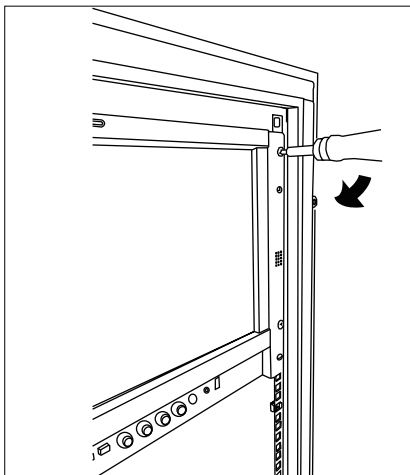

Figure 3

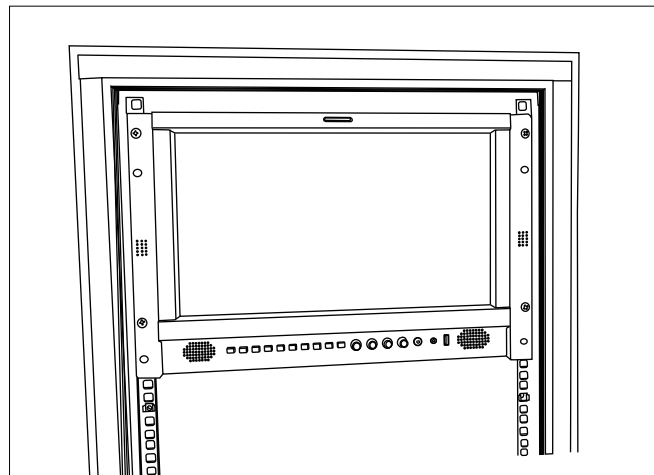
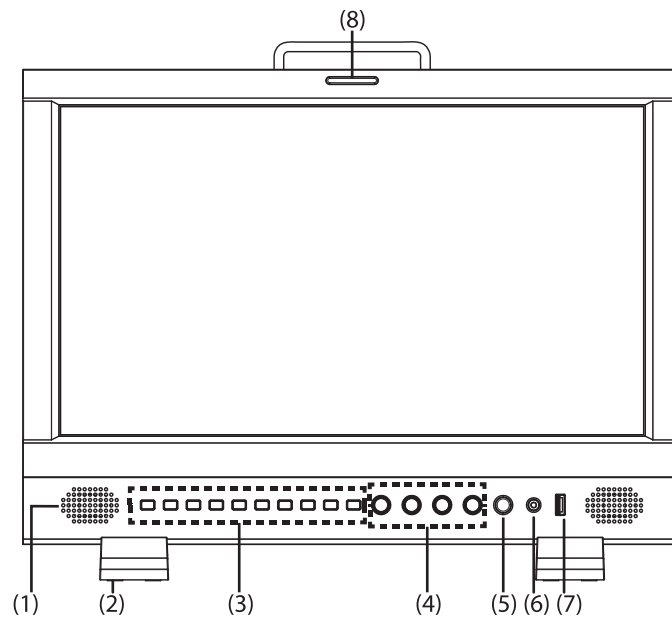

Figure 4

• Front Panel



(1) **Speaker:** For SDI/HDMI embedded audio. (Will not work if earphone is plugged in)

(2) **Desktop Stand Feet**

(3) **Illuminated Push Button**



SDI1~SDI4: Press each button to switch to the corresponding input source.

4XSDI/QUAD: Switch between square division and 2SI mode.

HDMI: Press to select HDMI input.

F1~F3: User definable function keys; please see details in “6.Control” under “Main Menu”.

Eg: when F1 is defined as “histogram”, press F1 to turn on histogram, and press F1 twice to turn off it.

INFO: Press “INFO” to turn on or turn off relevant status, audio and video oscillograms.

Press “INFO” to release one key quit the menu when Menu is opened.

(4) **Rotary Knob**

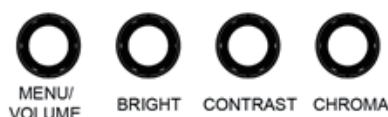

MENU/VOLUME: When the menu is inactivated, press “MENU/VOLUME” to turn on the main menu. Revolve “MENU/VOLUME” to adjust settings or parameters, and press to apply.

When the menu is inactivated, revolve “MENU/VOLUME” to adjust the sound volume.

BRIGHT: -100-100 value adjustment and the default value is 0.

CONTRAST: -100-100 value adjustment and the default value is 0.

CHROMA: -100-100 value adjustment and the default value is 0.

(5) **POWER:** Press to switch on or switch off the monitor.

(6) **PHONE jack:** 3.5mm earphone socket, for SDI/HDMI embedded audio.

(7) **USB LUT:** for firmware upgrading and upload 3DLUT cube files.

(8) **TALLY lamp:** This lamp is controlled by the tally function of the Make contact terminal.

(You can select the color of the tally lamp from "Green", "Red", or "Yellow").

• OSD

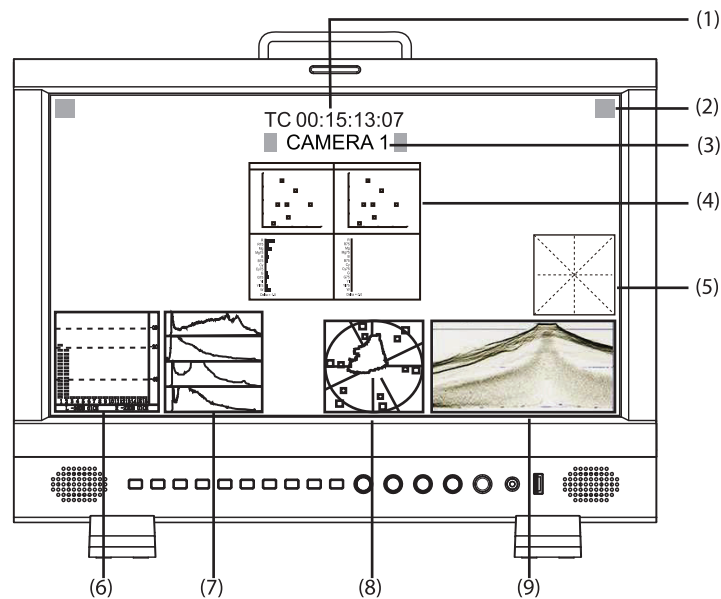

(1) Time Code (SDI)

Under SDI input, the monitor can display Time code information (LTC, VITC1&2). If no Time code info is detected, it will display “TC UNLOCKED”.

User can set function keys F1~F3 or GPI pins as “Time Code” to turn on or off this function.

(2) On screen TALLY

Display TALLY signal from GPI port.

(3) UMD

Display TSL 3.1/4.0 UMD or User input Source ID.

(4) Color Checker

Display color gamut chart and Delta chart for last calibrated value and current measured value.

(5) Lissajous

Display audio Lissajous pattern.

(6) Audio VU/PPM meters

Display meters of SDI/HDMI embedded audio or analog audio. The audio meter display channels, on screen positions, markers and background colors are adjustable.

User can set function Keys F1~F3 or GPI pins as “Audio Bar” to turn on or off this function.

(7) Histogram

Parallel display R/G/B/Y histogram for SDI and HDMI video.

User can set function Keys F1~F3 or GPI pins as “Histogram” to turn on or off this function.

(8) Vector scope

Display vector scope with 100% and 75% markers for SDI and HDMI video. The vector scope pattern display positions, colors, background are adjustable.

User can set function Keys F1~F3 or GPI pins as “Vector” to turn on or off this function.

(9) Waveform

Display waveform scopes for SDI and HDMI video with markers. The display waveform can be selected from Y/Cb/Cr/R/G/B types, and single line display mode selectable. The waveform display positions, colors, background are adjustable.

User can set function Keys F1~F3 or GPI pins as “Waveform” to turn on or off this function.

Introduction of audio and video functions

■ 16-ch embedded audio meters

Under SDI and HDMI, it displays 16 channels embedded audio meters. The audio meter is green, and will turn yellow when audio exceeds -20dB, and turn red when audio exceeds -9dB.

■ Time code (SDI)

Under SDI input, it can display the SMPTE time code (VITC1, VITC2 or LTC) on the top of the screen, which is used extensively for synchronization, and for logging and identifying material in recorded media. If no Timecode information is detected, it will be displayed as “TC UNLOCKED”.

■ Waveform (Y, Cb, Cr, R, G, B)

Under SDI and HDMI input, totally 6 kinds of waveforms which are Y, CB, CR, R, G and B can be selected so as to check the brightness and chroma distribution.

■ Vector

The displayed vector scope pattern is available under both SDI and HDMI, represents saturation as distance from the center of the circle, and hue as the angle, in standard position, around it.

■ Histogram (R, G, B)

The histogram is a bar graph that shows the distribution of luminance values in the picture. There're R, G, B histograms that individually displayed simultaneously, available under both SDI and HDMI.

■ Peaking focus assist (red/blue switch)

The Peaking focus assist function is to mark the sharpest edges of the image with red or blue color under SDI and HDMI input, for users to check if the subjects are focused.

User can set function Keys F1~F3 or GPI pins as “Focus Assist” to turn on or off this function.

■ Zebra stripes

Zebra Stripes are used to check if the image is over exposed or not by showing black and white lines on the monitor. It is considered over exposed when luminance value exceeds 90%.

User can set function Keys F1~F3 or GPI pins as “Zebra” to turn on or off this function.

■ False Color

The false color is used to aid in the setting of camera exposure. Under false color mode, there's a color chart on the bottom of screen for reference. The color from the dark to the bright will be displayed as blue, cyan, green, yellow, orange and red in a consecutive way. User can set function Keys F1~F3 or GPI pins as “False color” to turn on or off this function.

■ H/V Delay (SDI)

Under SDI input, H/V Delay can be used to display line/field blanking signal, and to observe the horizontal and vertical synchronous signal.

■ UMD

When using external control unit, it can display the video source ID and tally information on the screen.

■ Odd/Even Frame

Display the current status of Odd/Even Frame: ON/OFF.(Will display gray and not available if the current input signal doesn't support Odd/Even mode)

• Rear Panel

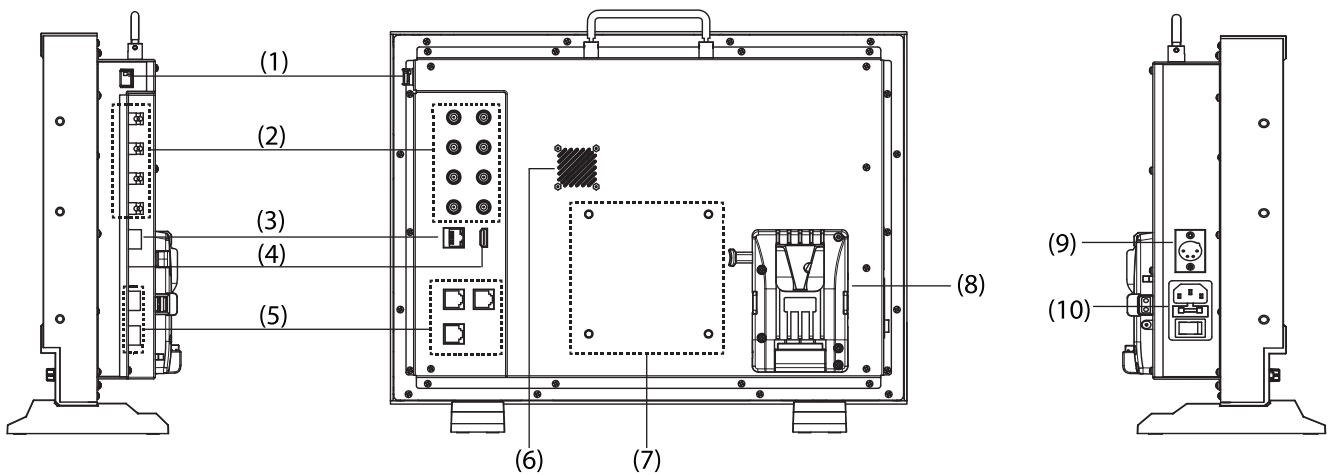

(1) SFP port

Input terminal for 12G/6G/3G/HD/SD-SDI SFP optical fiber receiver adaptor.

★ The SFP adaptor is optional purchased.

(2) SDI IN&OUT:

12G-SDIx2 (IN&OUT)

3G-SDIx2 (IN&OUT)

(3) ETHERNET:

1000M high speed RJ45 ethernet port, for webserver IP external control.

(4) HDMI 2.0 IN

★ Will not display HDCP protected contents.

(5) External control port

RS-485 (IN、OUT) : TSL UMD control port

GPI: GPI control port

(6) Fans

(7) VESA mount area

(8) Battery plate

(9) DC IN: 12V~17V

(10) AC IN: 100V~240V

Main Menu

BM-U173 has OSD to adjust the parameters and settings, for example: Picture, Scanning, Assist, etc.

1. Press “MENU/ VOLUME” button, the main menu will pop up from the left top of the screen. The selected main menu highlights in yellow.

Main Menu	Status
Exit&Status	Format XXX
Input	Channel XX
Picture	Color Temp XXXX
Color Management	Scanning XXX
Scanning	F1 XX
Control	F2 XX
Assist	F3 XX
De-embed	Version XX
Auto Calibration	
System	

2. Revolve “MENU/ VOLUME” to select submenu, the selected submenu highlights in yellow, press “MENU/ VOLUME” to apply and enter into the selected submenu’ s items.
3. Revolve “MENU/ VOLUME” to select the item which needed to adjust, press “MENU/ VOLUME”, the selected item and its parameters will be highlighted in yellow.

Main Menu	Assist	Vector
Exit&Status	Exit	Exit
Input	False Color OFF	Vector OFF
Picture	Blue Only OFF	CIE OFF
Color Management	Focus Assist OFF	Vector Position Bottom Right
Scanning	Zebra OFF	Vector Blending OFF
Control	Color Checker OFF	Vector Color Color
Assist	Waveform >	
De-embed	Vector >	
Auto Calibration	Histogram >	
System	Marker >	

4. Revolve “MENU/ VOLUME” to change the selected item’ s parameter, press “MENU/ VOLUME” to apply and save the settings.
- 5 Revolve “MENU/ VOLUME” to select “Exit”, press “MENU/ VOLUME” to quit submenu. Select “Exit & Status” under the Main Menu and press to quit Main Menu.

Notice:

- * The items in gray can not be set up.
- * If there is no operation under the setted time, the menu will automatically save settings and quit.
- * If the key inhabit function is turned on, except key inhibit function, all other items are in grey. Please turn off the key inhabit function to adjust the items.

Submenu introduction (the default values are marked with underline)

1.Exit&Status

Displays the current status, the details are as down below:

Exit&Status	Format	no signal
	Channel	SDI1
	Color Temp	D65
	Scanning	Panel Fit
	F1	Audio Bar
	F2	Vector
	F3	Lissajous
	Version	v5.5.10r

Format: Input video format, If no video detected in current inputs source, it will display “No Signal”.

Channel: Display the current channel.

Color Temp: Display the current Color Temperature.

Scanning: Display the current scanning mode.

F1~F3: Display the current functions that assigned to F1~F3 function keys.

Version: Display the current firmware version.

2.Input

Input	Exit	
	Input Range	0-1023, 4-1019, <u>64-940</u> , 64-1023
	YUV Color Matrix	<u>Auto</u> , BT.601,BT.709,BT.2020
	Red Gain	-100~100, <u>0</u>
	Green Gain	-100~100, <u>0</u>
	Blue Gain	-100~100, <u>0</u>
	Red Bias	-100~100, <u>0</u>
	Green Bias	-100~100, <u>0</u>
	Blue Bias	-100~100, <u>0</u>
	Reset	

Exit: Return to Main Menu.

Input Range: Video Lumina Range setting.

YUV Color Matrix: Choose color matrix.

Red Gain: Adjust the Red Gain.

Green Gain: Adjust the Green Gain.

Blue Gain: Adjust the Blue Gain.

Red Bias: Adjust the Red Bias.

Green Bias: Adjust the Green Bias.

Blue Bias: Adjust the Blue Bias.

3.Picture

To adjust picture parameters.

Picture	Exit	
	Contrast	-100~100, <u>0</u>
	Brightness	-100~100, <u>0</u>
	Chroma	-100~100, <u>0</u>
	Sharpness	0~100, <u>0</u>
	Backlight	0~100, <u>16</u>

Exit: Return to Main Menu.

Contrast: Adjust the contrast of the display.

Brightness: Adjust the brightness of the display.

Chroma: Adjust the saturation of the display.

Sharpness: Adjust the sharpness of the display.

Backlight: Adjust the backlight of the display.

4. Color Management

Color Management	Exit	
	Color Gamut	<u>L</u> CD Panel, DCI-P3, Rec.709, Rec.2020
	Gamma	1.0, 1.8, <u>2.2</u> , 2.4, 2.6, PQ1000, HLG1000, S-Log3
	SoftClip(300nit)	<u>O</u> FF, <u>O</u> N
	HLG System Gamma	1.0, 1.1, <u>1.2</u> , 1.3, 1.4, 1.5
	Log Mode	<u>O</u> FF, J-Log1, Log-C, S-Log2, C-Log, V-Log, RedLogFilm, S-Log3, User-Log
	Color Temp	2000K~10000K, USER1, USER2, D93, D75, <u>D65</u> , D55
	User Temp	2000K~10000K, USER1, USER2, D93, D75, D65, D55
	Red Gain	-100~100, <u>0</u>
	Green Gain	-100~100, <u>0</u>
	Blue Gain	-100~100, <u>0</u>
	Red Bias	-100~100, <u>0</u>
	Green Bias	-100~100, <u>0</u>
	Blue Bias	-100~100, <u>0</u>
	Reset	
	Import	<u>N</u> one, 3DLut.cube, J-Log1.Cube, Log-C.cube, S-Log2.cube, S-Log3.cube, C-Log.cube, V-Log.cube, RedLogFilm.cube, User-Log.cube
	Reset	<u>N</u> o, 3DLut.cube, J-Log1.Cube, Log-C.cube, S-Log2.cube, S-Log3.cube, C-Log.cube, V-Log.cube, RedLogFilm.cube, User-Log.cube

Exit: Return to Main Menu.

Color Gamut: Select the color gamut mode.

Gamma: Select the Gamma correction value. Soft Clip(300nit) optional when gamma mode is set to PQ1000, adjust HLG System Gamma mode is set to HLG1000.

Log Mode: Camera Log conversion

When shooting with Log mode of the camera, you can select the corresponding Log conversion LUT, to convert the log mode video to standard ITU Rec.709 mode to monitor. A "User-Log" is provided for user defined LUT converting to Rec.709.

Color Temp: Select the color temperature mode.

User Temp: Select the color temperature mode of User Temp. (Adjustable when the color temperature is set to user mode)

Red Gain: Adjust the Red Gain under User Temp.

Green Gain: Adjust the Green Gain under User Temp.

Blue Gain: Adjust the Blue Gain under User Temp.

Red Bias: Adjust the Red Bias under User Temp.

Green Bias: Adjust the Green Bias under User Temp.

Blue Bias: Adjust the Blue Bias under User Temp.

Import: Upload cube

Put the cube file in U-disk root directory, plug U-disk into USB port, select the cube file and upload it.

Reset: Reset to factory cubes

For any wrong cubes imported that caused wrong display colors, you can reset the cubes to factory cubes here.

5. Scanning

Scanning	Exit	
	Scanning	<u>Panel Fit</u> , H Fit(4K), Native
	Zoom Mode	<u>OFF</u> , Top Left, Top, Top Right, Left, Center, Right, Bottom Left, Bottom, Bottom Right
	Flip Mode	<u>OFF</u> , ON
	Freeze Frame	<u>OFF</u> , Top Half, Bottom Half, Full
	Odd/Even Frame	<u>OFF</u> , Odd Mode, Even Mode

Exit: Return to Main Menu.

Scanning: Scan mode setting.

Zoom Mode: Zoom in on the selected area.

Flip Mode: Flip mode setting.

Freeze Frame: Freeze Frame setting.

Odd/Even Frame: Select Odd/Even Frame mode.

6. Control

Control	Exit	
	GPI Control	<u>OFF</u> , ON
	GPI 1Pin	<u>HDMI</u>
	GPI 2Pin	<u>SDI1</u>
	GPI 3Pin	<u>SDI2</u>
	GPI 4Pin	<u>SDI3</u>
	GPI 5Pin	<u>SDI4</u>
	GPI 6Pin	<u>4xSDI(2-SI)</u>
	Tally Setting	<u>OFF</u> , ON, Blinking
	Tally Position	<u>Top</u> , Bottom
	F1	<u>Audio Bar</u>
	F2	<u>Vector</u>
	F3	<u>Lissajous</u>
	UMD	<u>OFF</u> , ON
	UMD Color	White, <u>Red</u> , Green, Blue, Black, Gray
	UMD Position	<u>Top</u> , Bottom
	UMD Size	<u>Large</u> , Small
	UMD Blending	<u>OFF</u> , LOW, HIGH
	Display Type	<u>Source ID</u> , UMD
	RS485 Address	1
Baud Rate	115200,8,n,1	
Source ID	CAMERA 1	

Exit: Return to Main Menu.

GPI Control: Enable GPI control.

GPI 1Pin~GPI 6Pin: Assign functions to the GPI terminals.

The GPI pins can be set to the down below functions:

SFP, SDI1, SDI2, SDI3, SDI4, 4×SDI(2-SI)、4×SDI(SQ), HDMI, Red Tally, Green Tally, Yellow Tally, Time Code, Freeze Frame, WFM Type, WFM Single Line, UMD, Marker, Waveform, Audio Bar, Zebra, Vector, Low Latency Mode, Histogram, Lissajous, Focus Assist, False Color.

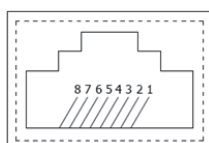

Pin	1	2	3	4
GPI	GPI_1	GPI_2	GPI_3	GPI_4
Pin	5	6	7	8
GPI	GPI_5	GPI_6	NC	GND

Tally: Turn the tally display on/off.

Tally Position: Tally display position setting.

F1~F3: Assign functions to the function keys F1 – F3 on the front key board. F1-F3 can be setted as the down below functions:

Time Code, Color Temp, Flip Mode, Freeze Frame , Waveform, Waveform Type , UMD, Marker, H/V Delay, Blue Only, Audio Bar, Zebra, Vector, Low Latency mode, Histogram, Odd/Even Frame , Lissajous, Focus Assist ,False Color.

UMD: Turn the tally display on/off.

UMD Color: Color setting.

Position: Display position setting.

Size: Size setting.

UMD Blending: Adjust the UMD background transparency.

Display Type: Choose display type.

(1)Select “UMD” to display Source info and Tally info from external control devices of TSL protocol.

(2)Select “Source ID” to display a user input fixed source info, and Tally info by GPI input.

RS485 Address: Fixed value.

Baud Rate: Fixed value.

Source ID: Setting of “Source ID”.

RS485 pin sequence and definition:

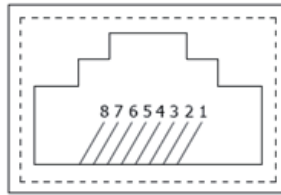

Pin	IN	OUT
1	GND	GND
2	NC	NC
3	RXD-	RXD-
4	NC	NC
5	NC	NC
6	RXD+	RXD+
7	TXD-	TXD-
8	TXD+	TXD+

7.Assist

Assist	Exit	
	False Color	OFF, ON
	Blue Only	OFF, ON
	Focus Assist	OFF, Blue,Red
	Zebra	OFF, ON
	ColorChecker	OFF, ON
	Waveform	>
	Vector	>
	Histogram	>
	Marker	>

Exit: Return to Main Menu.

False Color: Turn on/off False color mode.

Blue Only: Turn on/off Blue only mode.

Focus Assist: Turn on/off focus assist mode and select focus line color.

Zebra: Turn on/off zebra stripes for over exposure check.

Color Checker: Turn on/off color checker.

Waveform:

Waveform	Exit	
	Waveform	OFF, ON
	WFM Type	Y, Cb, Cr, R, G, B
	WFM Position	Bottom Left, Bottom Right, Top Left, Top Right
	WFM Blending	OFF, LOW, HIGH
	WFM Color	White, Color, Green
	WFM Single Line	OFF, ON
	WFM Line Count	1

Exit: Return to Assist submenu.

Waveform: Turn on/off waveform pattern.

WFM Type: Select WFM type.

WFM Position: WFM Position setting.

WFM Blending: Adjust the WFM pattern background transparency.

WFM Color: Waveform pattern color setting.

WFM Single Line: Turn on/o the Waveform single line mode.

WFM Line Count: Select a line for the single line waveform.

Only the “WFM Single Line” is set to “ON”, the “WFM Line Count” can be adjusted.

“WFM Single Line” is to display the selected line waveform of “WFM Line Count”

(Line number of single line relates to the signal format)

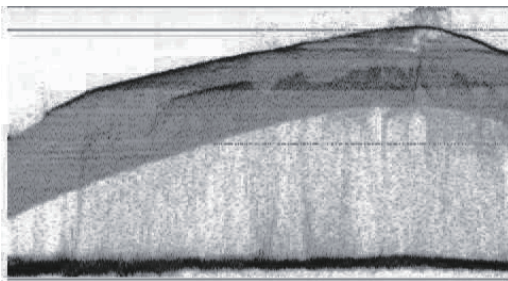

WFM Single Line:Off

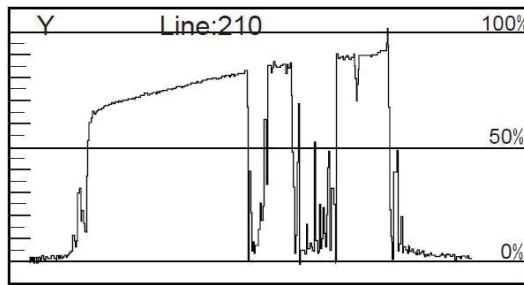

WFM Single Line:On

Vector:

Vector	Exit	
	Vector	<u>OFF</u> , ON
	CIE	<u>OFF</u> , ON
	Vector Position	<u>Bottom Left</u> , Bottom Right, Top Left, Top Right
	Vector Blending	<u>OFF</u> , LOW, HIGH
	Vector Color	<u>White</u> , Color, Green

Exit: Return to Assist submenu.

Vector: Turn on/off the Vector scope pattern.

Vector Position: Vector scope pattern on screen display position setting.

Vector Blending: Vector scope pattern background transparency selection

Vector Color: Vector scope pattern color setting.

Histogram:

Histogram	Exit	
	Histogram	<u>OFF</u> , ON
	Histogram Blending	<u>OFF</u> , LOW, HIGH

Exit: Return to Assist submenu.

Histogram: Turn on/off the Histogram pattern.

Histogram Blending: Histogram pattern background transparency selection.

Marker:

Marker	Exit	
	Marker	<u>OFF</u> , ON
	Marker Select	Custom, 2:1, 4:3, 13:9, 14:9, 15:9, <u>16:9</u> , 1.85:1, 2.35:1
	Horizontal	50%~99%, <u>99%</u>
	Vertical	50%~99%, <u>99%</u>
	Safety Area	80%~99%, <u>80%</u>
	Fit Marker	<u>OFF</u> , ON
	Center Marker	<u>OFF</u> , ON
	Marker Color	<u>White</u> , Red, Green, Blue, Black, Gray
	Marker Outside	<u>OFF</u> , Black, Gray

Exit: Return to Assist submenu.

Marker: Turn the marker display on / off. When the marker is set to the user, the proportion of horizontal axis and vertical axis can be adjusted.

Marker Select: Adjust the ratio of marker.

Safety Area: Safety area setting.

Fit Marker: Set safety area to fit marker ratio or not.

Turn off the Fit Marker, the safety area size percentage is based on screen size.

Turn on the Fit Marker, the safety area size percentage is based on Marker ratio.

Center Marker: Turn the center cross mark on / off.

Marker Color: Marker color setting.

Marker Outside: Marker outside color setting.

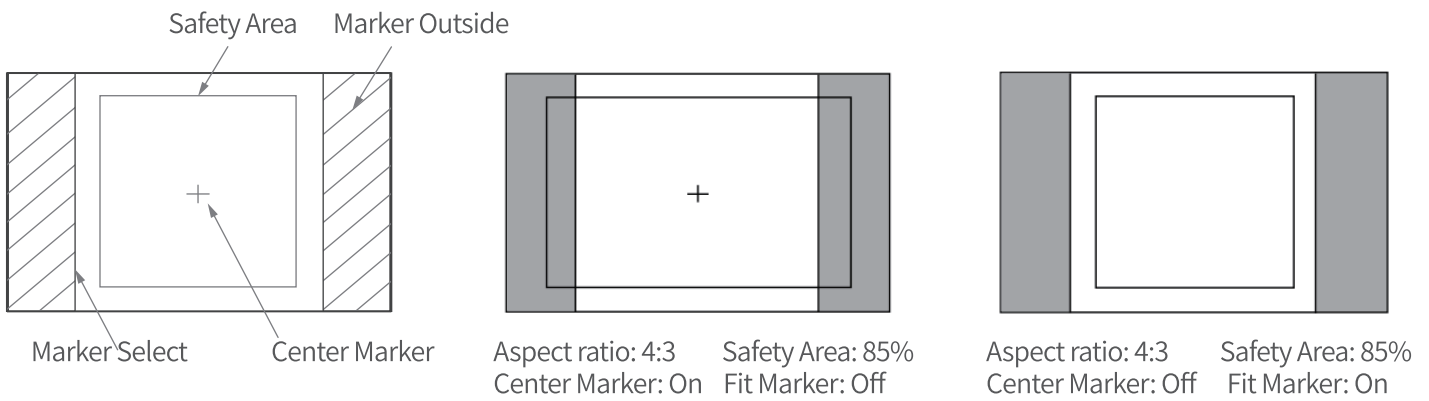

8.De-embed

De-embed	Exit	
	Lissajous	<u>OFF</u> , <u>ON</u>
	Lissajous Position	<u>Top Left</u> , <u>Top Right</u> , <u>Bottom Left</u> , <u>Bottom Right</u>
	Audio Bar	<u>OFF</u> , <u>ON</u>
	Bar Position	<u>Top Left</u> , <u>Top Right</u> , <u>Bottom Left</u> , <u>Bottom Right</u>
	Bar Blending	<u>OFF</u> , <u>LOW</u> , <u>HIGH</u>
	Bar Type*1	<u>TYPE1</u> , <u>TYPE2</u>
	Left Channel	Channel 1~Channel 16, <u>Channel 1</u>
	Right Channel	Channel 1~Channel 16, <u>Channel 2</u>
	Volume	0~100, <u>36</u>
	Time Code	<u>OFF</u> , <u>ON</u>
	H/V Delay	<u>OFF</u> , <u>ON</u>

Exit: Return to Main Menu.

Lissajous: Turn on/turn off Lissajous.

Lissajous Positions: Change on screen display position of Lissajous.

Audio Bar: Turn on / turn off the audio bar display.

Bar Position: Change on screen display position of the audio bar.

Bar Blending: Adjust the audio bar pattern background transparency.

Bar Type: Turn on / turn off the audio bar frame and marks.

Left Channel/ Right Channel: Select the audio left and right channel to be de-embed and output via speaker or headphone.

Volume: volume setting.

Time Code: turn on/off Time code display.

H/V Delay: turn on/off H/V delay display.

9.Auto Calibration

Auto Calibration	Exit	
	Probe Select	<u>X-rite I1 Pro OEM</u> , <u>Jeti Specbos 1211</u>
	Start Calibration	<u>NO</u> , <u>YES</u>
	Measure	<u>NO</u> , <u>YES</u>

Exit: Return to main menu.

Probe Select: Select the probe for color correction.

Start Calibration: Select "YES" to start color work.

Measure: The results of color correction were measured.

10. System

System	Exit	
	Key Lock	<u>OFF</u> , Full Lock, Rotation Key Lock, Key Button Lock
	Recall Profile	<u>Factory</u> , User 1~User 8
	Save Profile	<u>User 1~User 8</u>
	Low Latency Mode	<u>OFF</u> , ON
	Green Mode	<u>Black Backlight</u> , Gray Backlight
	Idle Duration	<u>30Sec</u> , 1Hour, 2Hour, 4Hour, OFF
	IP	192.168.001.200
	Net Mask	255.255.255.000
	Gateway	192.168.001.001
	Port (1024-65535)	08080
	OSD TIME	5~180, <u>30</u>
	Key Brightness	OFF, <u>LOW</u> , HIGH
	Language	<u>English</u> , 中文
	System Reset	<u>NO</u> , YES
	Update	<u>NO</u> , YES

Exit: Return to Main Menu.

Key Lock: Key inhibit setting.

Recall Profile: Loading Factory settings and User presets
Factory: Recover all settings to factory setting
User 1/2/3/4/5/6: Load the User settings 1/2/3/4/5/6.

Save Profile: Save current User settings

User 1/2/3: Save the current settings to User 1/2/3/4/5/6.

Low Latency Mode: Turn on /off Low Latency Mode.

Green Mode: Display settings when in Energy Save mode.

To comply with ECO save energy regulations, the monitor will go to Green Mode if there's no operation during a period of time. Press any button, the monitor will be back to normal status.

Idle Duration: Set an idle time to enter Energy Save mode

Select a time to enter Green Mode if there's no operation. Set to "OFF" will disable Green Mode, please double confirm.

IP/Net Mask/Gateway/Port: Set monitor IP address for webserver remote control.

OSD TIME: OSD Duration setting.

Key Brightness: Key Led Brightness setting.

Language: Set menu display language to Chinese or English.

System Reset: Reset OSD setting.

Update: Put the program into U-disk root directory, plug U-disk into USB port, go to System→Update→Yes. When it shows "Update Succeeded", upgrade finishes.

ETHERNET

- 1) Enter Menu- External Control - IP/Net Mask/Gateway/Port to set the monitor addresses. Set the computer Ethernet IP address at the same LAN environment as the Monitor.

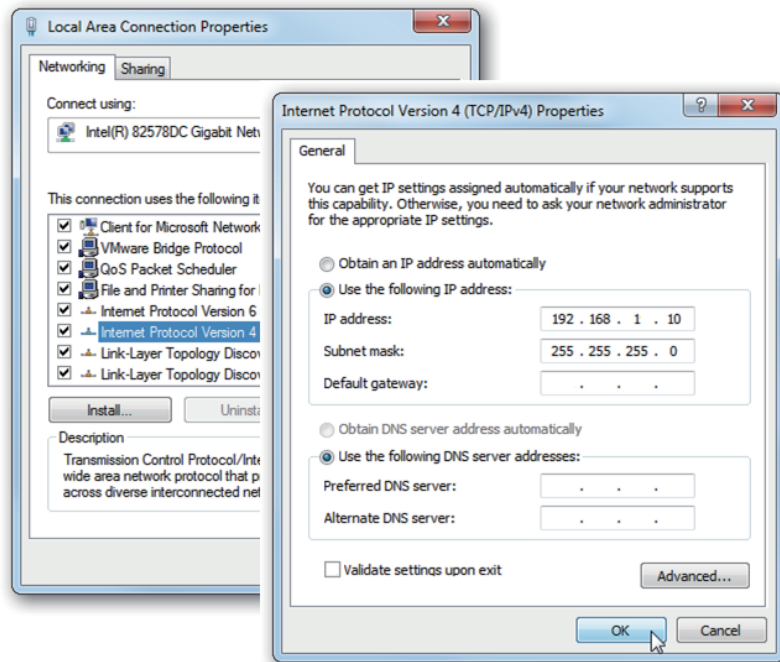

- 2) Launch any of a web browser on the computer, and enter URL: Monitor IP + port (for example 192.168.1.99:8080). The webserver control page will be displayed.

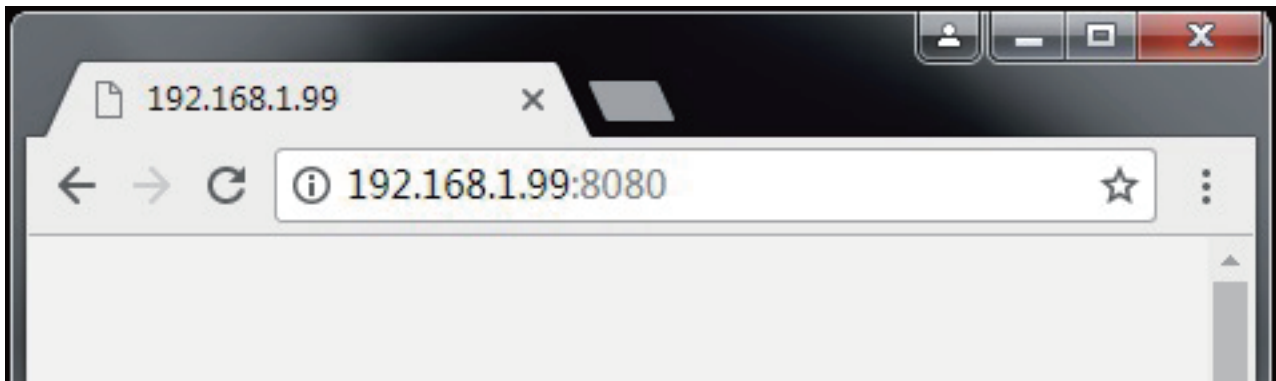

- Use crossed wired cable for computer-monitor directly connection.
- Use straight-through wired cable for Router connection.
- Please seek help from your webmaster for any network connections.

Webserver page control interface

SWIT.
BM-U series

Status

Settings
Network
Update

Input Source:

Input Format:

Loaded Profile:

Video Level Range:

YUV Color Matrix:

Volume:

Chroma:

Bright:

Contrast:

Freeze Frame:

Odd/Even Frame:

Low Latency:

Gamma:

Color Temp:

Log Mode:

Monitor IP:

Net Mask:

Gateway:

Port:

Refresh Status

Input Source: SDI1 SDI2 SDI3 SDI4 SQ 2-SI SFP HDMI

Loaded Profile: USER1 ▾

Function Key: F1 F2 F3 F4 F5 F6

Volume: Set 0 100

Chroma: Set -100 100

Brightness: Set -100 100

Contrast: Set -100 100

Frame: Freeze Frame OFF TopHalf BottomHalf Full

Odd/Even Frame Odd Even OFF

Low Latency ON OFF

Color: VideoLevelRange 0-1023 ▾ YUVColorMatrix Auto ▾

Gamma 1.0 ▾ Color Temp 3200K ▾

Log Mode OFF ▾

Settings

Network

Update

Monitor IP:

Net Mask:

Gateway:

Port: Set 1024-65535

Settings

Network

Update

Current Firmware Version: v3.20190225r

Notes:

1. Please make sure you have the Firmware on your local PC.
2. Recommend to do Firmware updates only with AC power support.
3. Never shutdown the power during the update progress.

Please following these instructions:

Search a new Firmware on your local folders: Browse

Press 'submit' to transfer the Firmware to the monitor: submit

The Firmware is now ready to install, press 'Update': Update

Specification

LCD Performance		
Size	17.3inches	
Display area	381.89x214.81 mm	
Resolution	3840×RGB×2160	
Display Colors	16.7M	
Aspect ratio	16:9	
Brightness	300 cd/m ²	
Contrast	800:1	
Viewing Angle	178°/178°	
Input/Output		
Input	BNC×2	12G/6G/3G/HD/SD-SDI×2
	BNC×2	3G/HD/SD-SDI×2
	HDMI×1	HDMI 2.0
	RS-485×2	GPI×1、UMD×1
Output	USB×1	
	BNC×2	12G/6G/3G/HD/SD-SDI×2
	BNC×2	3G/HD/SD-SDI×2
	RS-485×1	UMD×1
Video format		
HDMI	480p/576p	
	1080i (60/59.94/50)	
	720p (60/59.94/50)	
	1080p (60/59.94/50/30/29.97/25/24/23.98)	
	1080psf (30/29.97/25/24/23.98)	
	3840x2160(60/59.94/50/30/29.97/25/24/23.98)	
	4096x2160(60/59.94/50/30/29.97/25/24/23.98)	
SDI	SMPTE-425M-A/B	1080p (60/59.94/50)
	SMPTE-274M	1080i (60/59.94/50)
		1080p (30/29.97/25/24/23.98)
	SMPTE-RP211	1080psf (30/29.97/25/24/23.98)
	SMPTE-296M	720p (60/59.94/50)
	SMPTE-125M	480i (59.94)
	ITU-R BT.656	576i (50)
	SMPTEST2048-1:2011	2048×1080p (23.98/24/25/29.97/30/50/59.94/60)
	SMPTE ST2081-10	3840×2160p (23.98/24/25/29.97/30)
SMPTE ST2082-10	3840×2160p (50/59.94/60)	
Working voltage	AC:100V~240V	
	DC/battery :12V~17V	
Power consumption	60W	
Working temperature	0°C~+40°C	
Working humidity	10%~90%	
Storage temperature	- 15°C~ + 60°C	
Storage humidity	10%~90%	
Dimensions	431.7×311.3×97.9mm(monitor only)	
Net weight (w/o stand)	6.1Kg	

Trouble-shooting

symptom	Possible causes	Solution
No display	The power is not turned on	Please check if the power is connected, and then press "POWER" button to turn on the monitor
	Unstable power voltage	Reconnect to power supply
	BNC or HDMI cable loose contact or not correctly connected	Check and correctly connect the BNC or HDMI cable
	The attached battery is no power	Change battery
	Using DIY power supply but the polarity is reversed	Refer to the provided power supply, reconnect the power.
Image or color abnormal	Bad contact of BNC or HDMI cable	Change cable
	Video signal has Interference	Remove the interference source(s)
	Improper adjustment of the color parameters	Adjust the "Recall profile" to "Default" under "System" submenu
	Distortion of the image	Reset the Aspect ratio
	Set to Red/Green/Blue only or Mono	Turn the Blue only/ Red Only/ Green Only/Mono off under R/G/B/Mono submenu
	Turn on the "Focus Assist" function	Turn off the "Focus Assist" function
	Turn on the "False Color" function	Turn off the "False Color" function
No audio output	Bad contact of signal cable	Change signal cable
	Wrong connection or bad contact of Audio cable	Connect to the correct input socket